

# FZ-1 INSTALLATION GUIDE

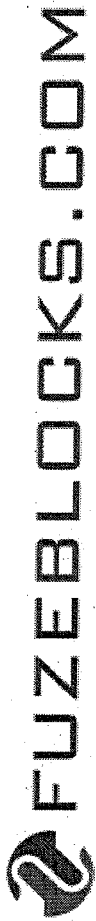

1. Disconnect the negative lead of the battery. Then remove the cover and mount the FZ-1 being sure that the back of the FZ-1, with the exception of the mounting posts, do not come into contact with metal or ground.

2. Connect a 12 gauge wire from the +12VDC input (J1) to the positive terminal of the battery. **Make sure to install an in-line fuse somewhere along the wire as close to the battery terminal as possible.**

3. Connect a 12 to 18 gauge wire (18 gauge is usually more than sufficient) from the +VT input (J1) to a switched power source on the vehicle. A switched power source is a wire that is +12 VDC when the vehicle is on and 0 VDC when the vehicle is off. Refer to your service manual, local mechanic and/or internet forum to find a suitable switched source for your particular vehicle and for the best procedure on tapping the wire. The switched source is used to energize the FZ-1's relay coil (about 1W) which will cause the relay contacts to close and supply +12VDC from the battery to the switched +12V output bus.

4. Connect a 12 gauge wire between the GND input (J1) and the negative terminal of the battery.

5. Insert the proper amperage fuse, for your device, into either the switched or constant fuse position on one of the 6 output circuits. Then connect the positive wire for your device to that circuit's output terminal (J2/J3).

6. Connect the ground wire for your device to the ground bus (J4/J5).

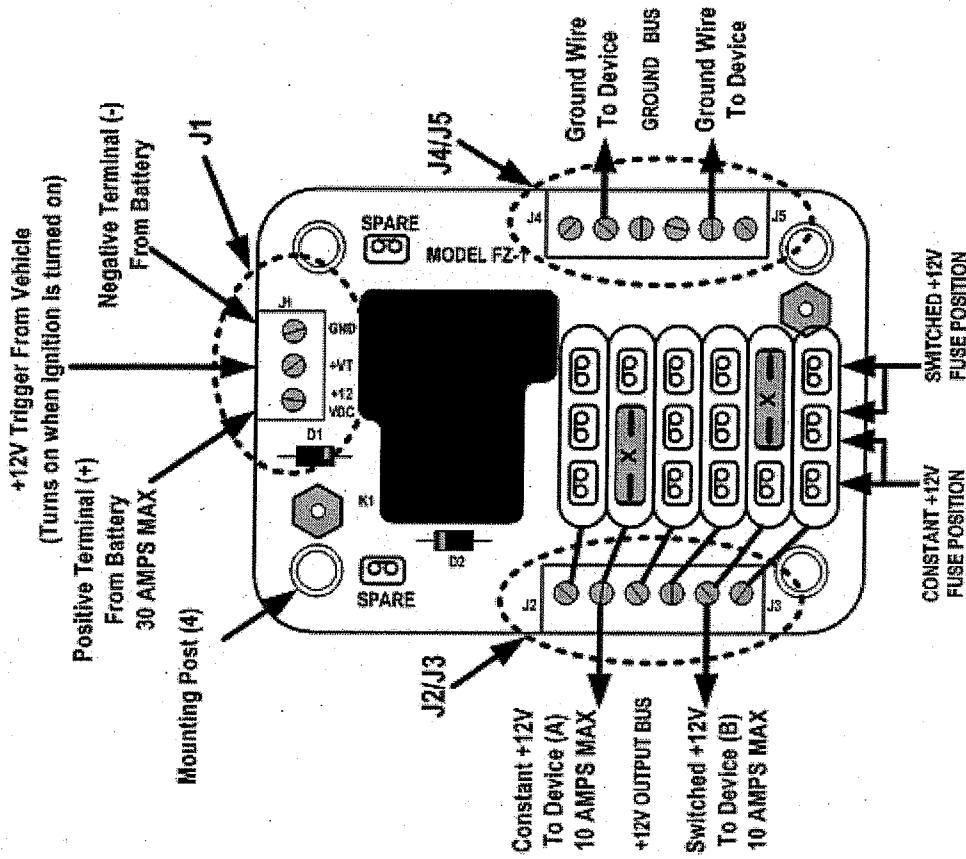

**NOTE: CHECK YOUR WIRING BEFORE APPLYING POWER TO THE FZ-1 OR TO ANY DEVICES. DO NOT EXCEED 30 AMPS TOTAL INPUT AND DO NOT EXCEED 10 AMPS ON ANY ONE OUTPUT.**

Please be responsible for your wiring. We have tried to make the FZ-1 easy to install but it is not indestructible. We cannot be held responsible for any damage or injury that results from improper or incorrect wiring. Please take the time to read all instructions before installing.